

UNIVERSAL

M O U N T I N G I N S T R U C T I O N S

REF 20334

FLANKER WINDSHIELD MODEL



ID	PIEZA/PART	DESCRIPCIÓN	DESCRIPTION	QTY	REF
1		Cúpula	Screen	1	9376H/W/F/NM3
2		Soporte izquierdo	Left support	1	SOPOR2P2-L20334
3		Soporte derecho	Right support	1	SOPOR2P2-R20334
4		Tapón de plástico	Plastic cap	2	TOPEE-VPGT--8/4
5		Tapa de plástico	Plastic cover	2	CONJU-S3PCC-003
6		Varilla Ø9 x 200	Ø9x200 Bar	2	VARILI9X200-591
7		Brida rotula L	L ball joint bridge	2	BRIROTO1-1-PR16
8		Brida rotula R	R ball joint bridge	2	BRIROTO2-1-PR16
9		Tornillo Philips 5x10mm	Ø5x10mm Philips screw	4	TORNIP510---233
10		Tornillo Allen Din912 M5x20mm	M5x20mm DIN912 Allen screw	4	TORNI-AD912-464
11		Tuerca autoblocante M5 DIN982 INOX	M5 DIN982 self-locking nut	4	TUERCA-D982-746
12		Semi-bridá corta	Short semi-bridle	2	BRIDAANT-0-PR16
13		Semi-bridá larga	Large semi.-bridle	2	BRIDAPOS-0-PR16
14		Casquillo semi-bridá para aplicar al manillar de Ø26	Semi.-bridle arrowhead applicate the handlebar Ø26	2	CAS29-22-0-PR16
15		Casquillo semi-bridá para aplicar al manillar de Ø22	Semi.-bridle arrowhead applicate the handlebar Ø22	2	CAS29-26-0-PR16
16		Pasador cilíndrico Ø4x20mm	Ø4x20mm cross dowel pin	2	VARILI4X20--576
17		Brida varilla	Dispstick bridge	2	FIXVARLL-0-PR16
18		Tornillo Allen M8x55 DIN912	M8x55 DIN912 Allen screw	2	TORNI-D912--631
19		Tuerca M8 autoblocante	M8 self-locking nut	2	TUEA-D985.8-M8-
20		Arandela de goma Ø4,5 x Ø11 x 2mm	Ø4,5 x Ø11 x 2mm Rubber washer	4	ARAND-EPDM--722
21		Arandelas de nylon M5	M5 nylon washer	4	ARNV0000000245
22		Tornillo Allen M5x11 Ø11 ISO 7380	M5x11 Ø11 ISO 7380 Allen screw	4	TORNI-AI----520
23		Tapón tornillo M5 ISO 7380	M5 ISO 7380 screw cap	4	TAPON-----85

UNIVERSAL

INSTRUCCIONES DE MONTAJE - MOUNTING INSTRUCTIONS - MONTAGEANLEITUNG

1

ASSEMBLY
MONTAJE

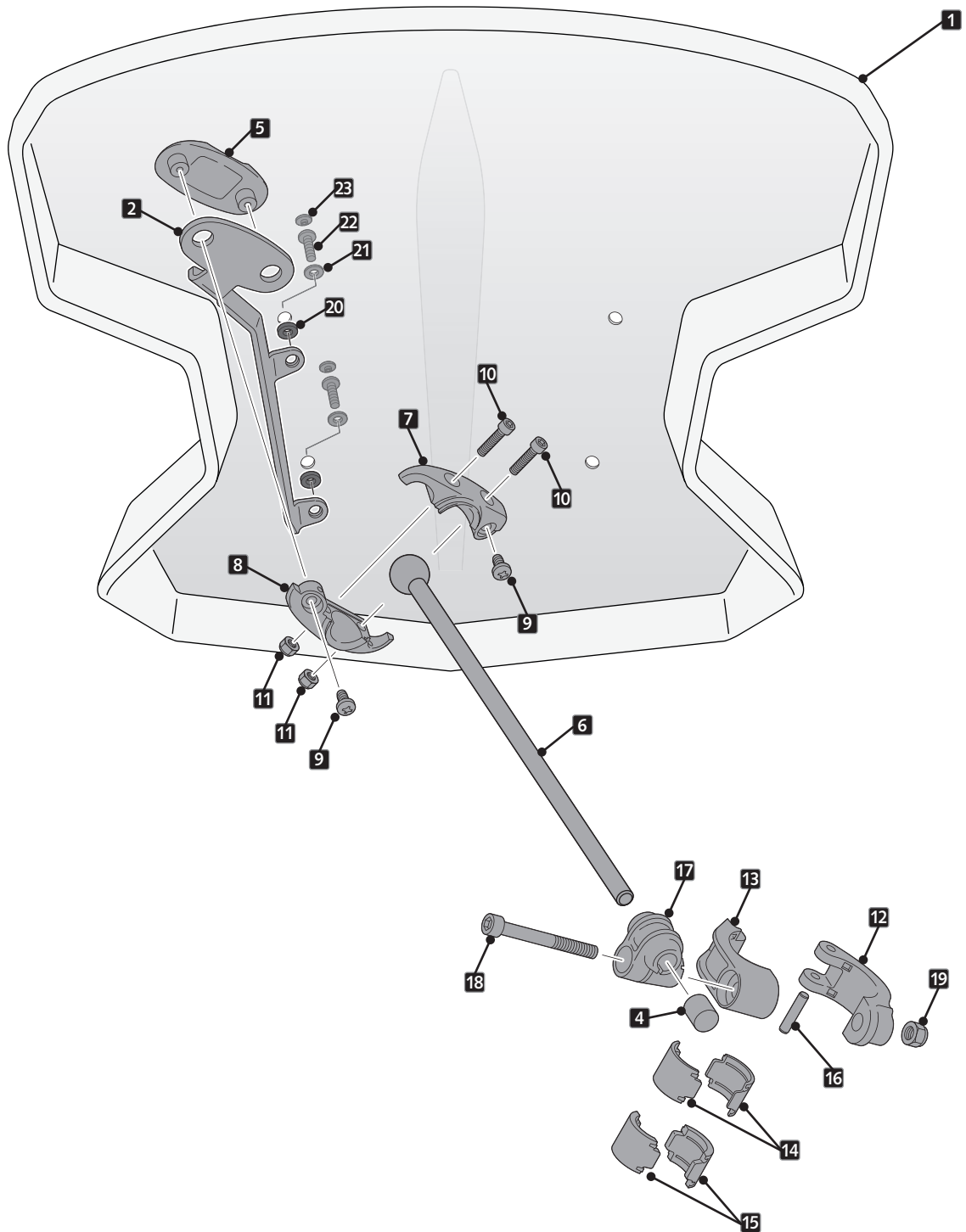

UNIVERSAL

INSTRUCCIONES DE MONTAJE - MOUNTING INSTRUCTIONS - MONTAGEANLEITUNG

2

ASSEMBLY
MONTAJE

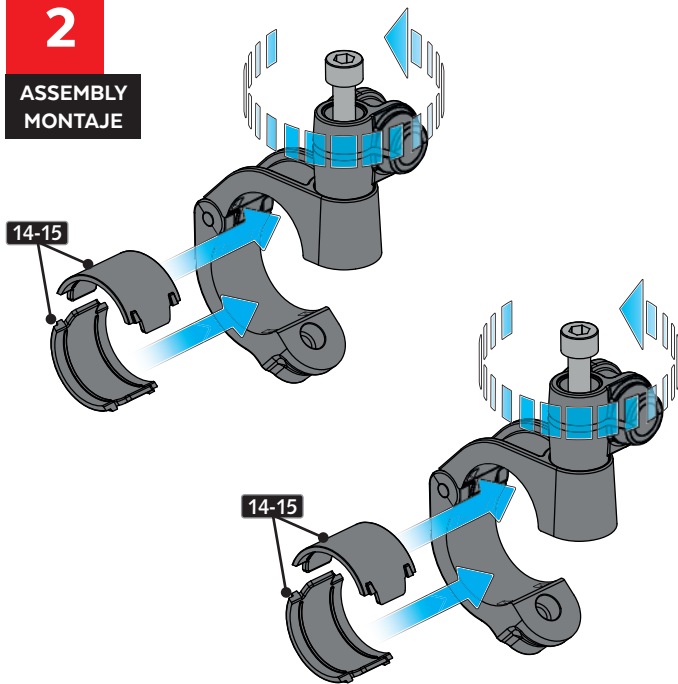

3

ASSEMBLY
MONTAJE

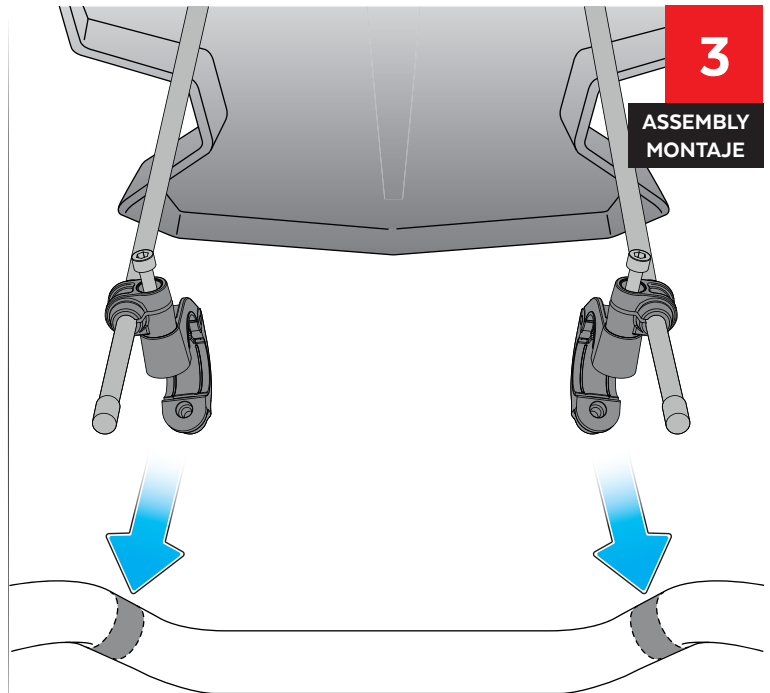

4

ASSEMBLY
MONTAJE

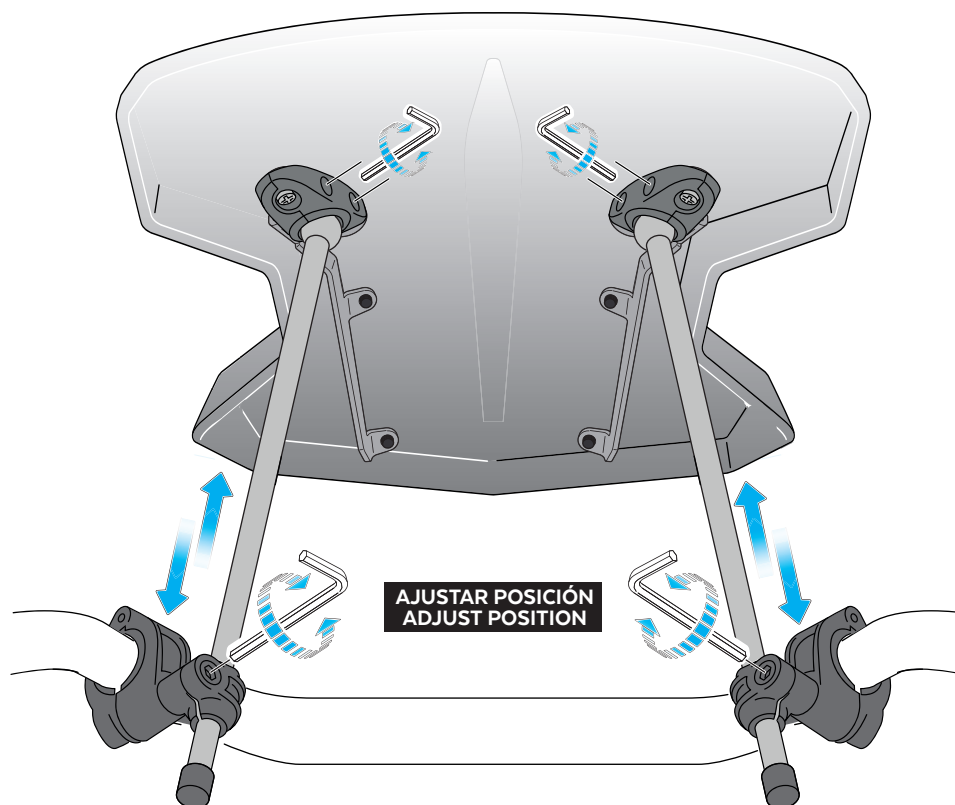

INAZUMA 250 '13-'17

M O U N T I N G I N S T R U C T I O N S

REF 10591

KIT FOR RAFALE / TREND / SHARK



ALLEN
Nº 3
Nº 5



PHILLIPS
SCREWDRIVER

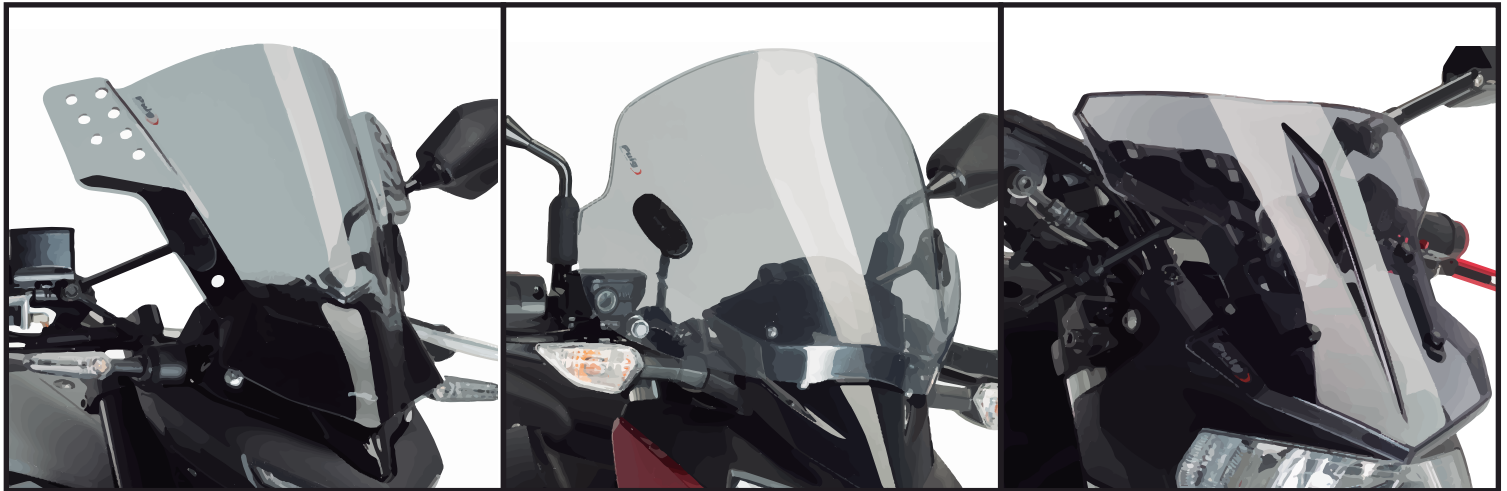

En las revisiones del vehículo es conveniente efectuar también el mantenimiento de apriete de toda la tornillería del carenabrís, especialmente los tornillos que fijan a éste al vehículo.
Gracias por su atención.

It would be convenient to re-tight the windshield screws, specially the ones that are fixed to the motorcycle, whenever you maintain the vehicle.
Thanks for your attention.

ID	PIEZA/PART	DESCRIPCIÓN	DESCRIPTION	QTY	REF
1		Tornillo Allen M6x40 DIN912	M6x40 DIN912 Allen Screw	2	TORNIAD912-0058
2		Acoplamiento escuadra	Coupling angle	2	FIXSOPOR-0-PR16
3		Escuadra	Angle	2	SOPORT65-1-0958
4		Arandela M6 DIN9021	M6 DIN9021 Washer	2	ARANDPD9021-037
5		Tuerca M6 DIN6923	M6 DIN6923 nut	2	TUERCAEM6G-0213
6		Tapón tuerca M6	Nut cap	2	CAPERUZTOM6-063

INAZUMA 250 '13-'17

INSTRUCCIONES DE MONTAJE - MOUNTING INSTRUCTIONS - MONTAGEANLEITUNG

1

ASSEMBLY
MONTAJE

